

# JAPANESE STAB BINDING

This technique is ideal for binding single sheets of paper in soft covers and can be used for diaries, class notes, phone messages, recipes, and school or business reports.

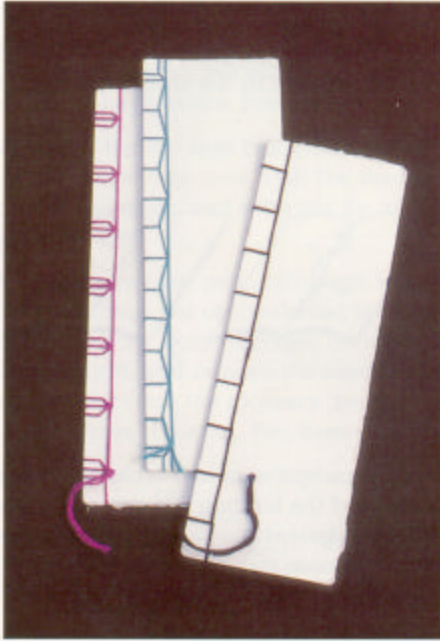

Most types of papers—handmade, commercial or tracing papers, even acetate can be used for Japanese stab binding. If the book will contain writing, the paper must be smooth. Inexpensive photocopy paper is also fine for text pages, and has the added benefit of being readily available and cut to a standard size. Cutting is not required for this technique, which makes it suitable for both young and beginner bookbinders.

Although the cover for this binding is always soft, it can be single sheets of heavy card-weight paper, single sheets with a turned-in flap, or sheets doubled over. The cover also can be one piece that wraps around the spine to give the pages more protection.

These Japanese stab books are bound with colored embroidery thread in three different variations of the binding, each with its own ame: the tortoise shell binding (left), the hemp leaf binding (center), and the traditional stab binding (right). Made from Fabriano printmaking paper for use as teaching samples. Adele Outteridge (Australia), 1993.  
11 1/4 x 3 3/4 x 1/4" (28.6 x 9.5 x 5

## MATERIALS

- 20–50 sheets of text paper, cut to the same size
- 70–100 lb (140–200 gsm) paper, for the front and back covers
- pencil
- triangle
- metal ruler
- craft knife with a new blade
- cutting mat
- leather hole punch, 1/16 to 1/8" (1 to 3 mm)—or electric drill and fine drill bit—and a small hammer (**Note:** the size of the holes depends on the thickness of the thread or yarn used for binding.)
- binding thread
- darning or tapestry needle
- scissors

## PREPARING TO BIND

- 1 Choose your cover option and the paper for the text pages. Based on its intended use and the paper available, decide the size of your book and the number of pages

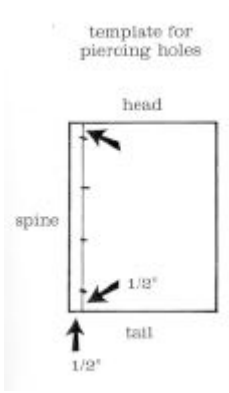
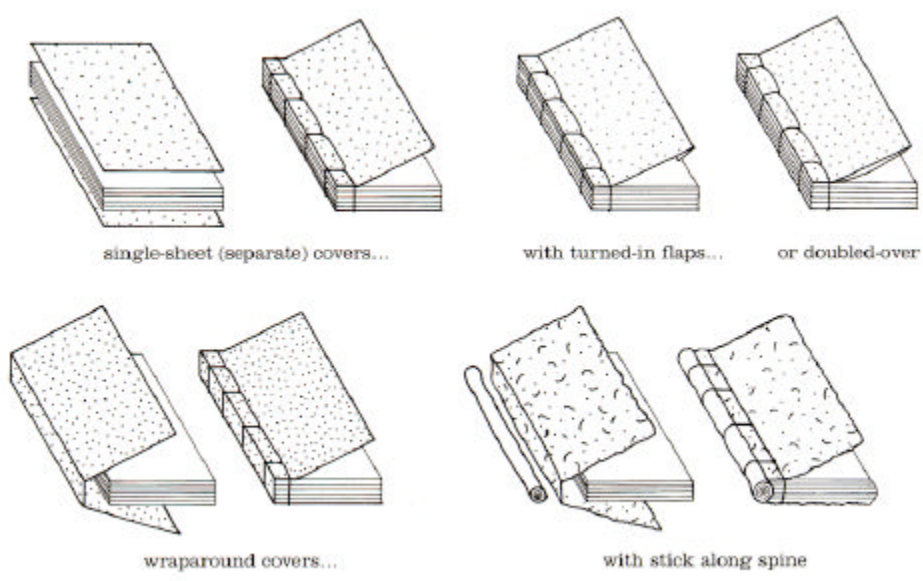

**2** Using the triangle, metal ruler, craft knife, and cutting mat, mark with a pencil and then cut all text pages to size, or start with paper cut to a standard size, such as 8 1/2 x 11" (metric A4)~ (See page 13-15.) Then cut two pieces of scrap paper to the same size as the text pages, reserving one for a template and the other to place underneath the text pages to protect them during handling.

**3** Using the triangle, ruler, and pencil, measure 1/2" (12 mm) from the left side of the template and draw a straight line. Measure 1/2" (12 mm) down from the head and 1/2" (12 mm) up from the tail, and mark these points on the line. These will be the lowest and highest sewing holes (*sewing stations*).

Measure the distance between these marks along the line. Divide that distance into equal parts and mark two other points along the line. These four marks on the template show where to punch holes. Four-hole binding is traditional, though five or more holes may be used.



68 A leather hole punch is used on this stack of text pages for a Japanese stab or an album binding. A simple template marks the position of the holes. Photo: E. Lancaster.

**4** Line up the text pages, and place them on thick cardboard or a wood board, not on a self-sealing cutting mat, which would become permanently damaged. Put the template on top of the text pages. Punch the holes with the leather hole punch and a small hammer, or with an electric drill.

With the leather hole punch, punch only twenty pages at a time. If you punch more, the pages-and the holes-will slip out of alignment. Use the template to mark the position of the holes for each lot of twenty pages. Check that each hole goes through all the pages.

In a classroom situation, the teacher can show two students or aides how to punch the holes; they then help everyone else with this step.

If you use a drill, place all the pages between two pieces of wood, with the top board just back from where the holes will be drilled. Place this sandwich on the edge of a bench or table and tighten a C-clamp around it and the bench; if you have two C-clamps, use one on either end. This will hold the pages in place while you drill. *If you are unfamiliar with power tools, ask someone who is familiar with them to help. Power tools can be dangerous if you do not know how to handle them.*

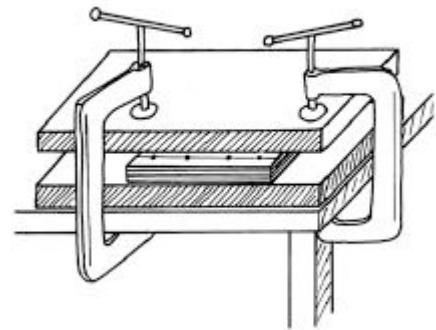

**5** Cut the cover paper 1/16" (2 mm) larger (both length and width) than the text pages. There is no overhang-or *square-on* covers with this binding; the covers are the same size or only a fraction larger than the text pages. Using the template, punch holes in the covers. Assemble the text pages, and put the covers in position.

### **BINDING IT TOGETHER**

**1** Cut a length of thread four times the height of the binding, and thread the needle. Hold the covers and the text pages together, and enter the lowest hole on the front cover, going through to the back. Pull the needle and thread through, leaving 2" (50 mm) of thread at the tail of the book. Thread around the tail, and through the same hole from the front cover. Thread around the spine and through the same hole again, coming out the back. Enter the next hole up from the back, and come out the front of the book.

**2** Thread around the spine, and enter the same hole again from the back, coming out the front. Enter the next hole from front to back. Thread around the spine, and enter the same hole again from front to back. Go up to the next, or top, hole, and enter from back to front.

**3** Thread around the spine and enter the same hole from the back, coming out the front. Thread around the head, and enter the same hole from the back. Your needle should be on the front, having just come out of the top hole. Go into the second hole down from front to back. On the back, go into the third hole down from back to front.

4 Move to the lowest hole, and remove the needle. Tie a square knot directly over the hole, leaving the tail of the thread. Cut the threads 1/4" (6 mm) away from the knot. Use the needle to tuck the ends into the hole.

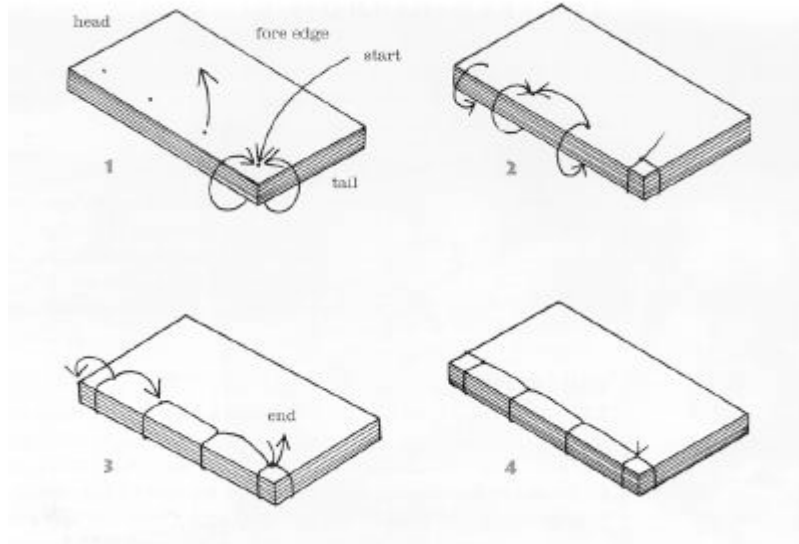

### CREATIVE IDEAS

- Vary the traditional Japanese stab binding by using different spacings and patterns of holes, or sewing stations.
- You can use many materials besides linen thread to bind these books and give them a unique look. The material must be strong enough to hold the binding, yet thin enough to thread through a needle. Before choosing a material, check that the sewing stations and the eye of the needle are large enough to accommodate it. Yarns, jute string, leather thongs, gimp, raffia, soft wire, thin ribbons, and fine braids may suit some books.
- Sew a stick, ribbon, or braid into the binding as a decorative feature. Add it along the spine if the book is thick enough, or put it on the front cover and hold it in place with the binding. (See fig. 6-1.) Be aware of how the book will be used and how the decorations might affect its use.



6-7 The artist photographed this wizened tree on a trip to Wales, used a color photocopier to reproduce it, and mounted it on the cover. Spray fixative can be used to protect photographic cover images. Helen McPherson (Australia) *Windswept*, 1989. Handmade paper text pages, Japanese stab binding, 7 x S 3/4 x 1/2(15 x 22 x 1 cm).

- Alternate page colors or use decorated papers and plain papers. Add shaped pages or pages of different materials to divide a book into sections.